



Level Switch

**NRS 2-50**

**NRS 2-51**

**EN**  
English

Original Installation &  
Operating Manual

**819179-06**

# Contents

Page

## Important notes

Usage for the intended purpose.....	4
Function.....	4
Safety note.....	4
Potentially explosive areas .....	5

## Technical data

NRS 2-50, NRS 2-51 .....	6
Product package .....	7
Example of name plate/identification.....	8

## Installation

Installation in the door of the control cabinet.....	9
Dimensions of the NRS 2-50, NRS 2-51 .....	10
Key .....	10
Installation in a control cabinet.....	10

## In the control cabinet: Wiring the level switch

Wiring diagram for level switch NRS 2-50 .....	11
Key .....	11
Wiring diagram for level switch NRS 2-51 .....	12
Key .....	12
Supply voltage connection.....	13
Connecting the output contacts.....	13
Connecting the level electrode/level transmitter .....	13
Connecting the actual value output .....	13
Tools .....	13

## In the system: Wiring the level electrode/transmitter

Connecting the level electrode/level transmitter .....	14
--	----

## Factory settings .....

# Contents

continued

Page

## Changing the factory settings

Switching the input and changing the function of the level electrode/transmitter ..... 15

## Operating the level switch

Meaning of codes on the 7-segment display ..... 17

Setting the measuring range ..... 18

## Bringing into service

Setting parameters ..... 19

Setting the measuring range ..... 20

## Operation, alarm and testing

Setting switchpoints and indicators ..... 21

Indications ..... 22

Checking the function of the MIN/MAX output contacts ..... 22

Password protection ..... 23

## Troubleshooting

Indications, diagnosis and remedies ..... 24

## Further information

Action against high-frequency interference ..... 25

Replacing/taking the equipment out of service ..... 25

Disposal ..... 25

## Declaration of Conformity

Directives and Standards ..... 26

## Important notes

### Usage for the intended purpose

The NRS 2-50, NRS 2-51 level switch is used in combination with NRG 2-.. level electrodes and NRGT 26-.. level transmitters as a limit switch and water level controller, e.g. in steam boilers and hot water installations or in condensate and feedwater tanks. The level switch indicates when a MIN and MAX water level has been reached, and switches the feedwater pump on and off (NRS 2-51).

The NRS 2-50, NRS 2-51 level switch can be combined with the NRG 21-.. and NRG 26-21 level electrodes and the NRGT 26-.. level transmitter.

### Function

The **NRS 2-50, NRS 2-51 level switch** processes the voltage signals from the NRG 2-.. level electrodes or the current signal from the NRGT 26-.. level transmitter. These voltage and current signals vary depending on the level.

In the **NRS 2-50, NRS 2-51 level switch**, the input signal is normalised to 0 and 100% of the boiler measuring range, and the switchpoints for the MIN/MAX water level are adjusted as required within this range. Then, during normal operation the actual value is shown on the 7-segment LED display.

If the MIN or MAX water level is reached, the MIN or MAX output contact switches over after the off delay and the MIN or MAX LED lights up.

The **NRS 2-51 level switch** also functions as an interval level control system (**fill/discharge, switch-selectable**). With this equipment, if the lower or upper water level switchpoint is reached, the controller output contact switches – depending on which function is set – which then turns the feedwater pump on or off. The amber LED lights up when the level switch has switched the feedwater pump on, for example. Faults or malfunctions in the level electrode or level transmitter, the electrical connection or the settings are indicated on the 7-segment LED display. In the event of a malfunction, the MIN and MAX alarm is triggered.

If faults occur only in the **NRS 2-50, NRS 2-51 level switch**, the MIN and MAX alarm is triggered and the system is restarted.

Parameters can be changed or the MIN/MAX alarm simulated by operating the rotary knob.

The equipment has an actual value output 4 - 20 mA for external level indication.

### Safety note

The equipment may only be installed, wired and brought into service by qualified and competent staff. Maintenance and setup work may only be performed by authorised staff who have undergone specific training.



#### Danger

The terminal strips of the equipment are live during operation.

There is a risk of serious injury due to electric shock!

Always **cut off power** to the equipment before working on the terminal strips (installation, removal, connecting cables).



#### Attention

The name plate indicates the technical features of the equipment. Do not bring into service or operate any equipment that does not bear its own specific name plate.

## Important notes

### Potentially explosive areas

The equipment must **not** be used in potentially explosive atmospheres.

## Technical data

### NRS 2-50, NRS 2-51

#### Supply voltage

24 VDC +/- 20%

#### Fuse

external 0.5A (semi-delay)

#### Power consumption

4 W

#### Connecting a level electrode/level transmitter (switch-selectable)

1 input for NRG 21-.. and NRG 26-21 level electrode, 3-pole with shield, or

1 analogue input 4-20 mA, e.g. for the NRGT 26-.. level transmitter, 2-pole with shield.

#### Supply voltage to level electrode

12 VDC

#### Outputs:

NRS 2-50, NRS 2-51: 2 volt-free relay contacts, 8 A 250 V AC / 30 V DC  $\cos \varphi = 1$ .

Off delay 3 seconds (MIN/MAX alarm, adjustable switchpoint).

NRS 2-51: 1 volt-free relay contact, 8 A 250 V AC / 30 V DC  $\cos \varphi = 1$ .

(e.g. feedwater pump on, adjustable switchpoints).

Inductive loads must have interference suppression (RC combination) as per the manufacturer's specifications.

NRS 2-50, NRS 2-51: 1 analogue output 4-20 mA, max. output load 500 ohms, e.g. for actual value indication.

#### Displays and controls

1 rotary knob with integrated pushbutton for testing the MIN/MAX alarm and setting the parameters,

1 four-digit seven-segment LED display, green

2 red LEDs for MIN/MAX alarm,

1 amber LED e.g. for feedwater pump on (NRS 2-51),

1 four-pole code switch for configuration.

#### Housing

Housing material: base of black polycarbonate; front of grey polycarbonate

Conductor size: 1 x 4.0 mm<sup>2</sup> solid per wire, or

1 x 2.5 mm<sup>2</sup> per stranded wire with sleeve to DIN 46228, or

2 x 1.5 mm<sup>2</sup> per stranded wire with sleeve to DIN 46228 (min.  $\varnothing$  0.1 mm)

Terminal strips can be removed separately

Housing attachment: Mounting clip on support rail TH 35, EN 60715

#### Electrical safety

Pollution degree 2 for installation in control cabinet with protection rating IP 54, fully insulated

#### IP rating

Housing: IP 40 to EN 60529

Terminal strip: IP 20 to EN 60529

With panel adapter: IP 65 to EN 60529

#### Weight

approx. 0.2 kg

## Technical data continued

### NRS 2-50, NRS 2-51 continued

#### **Ambient temperature**

when system is switched on 0 ° ... 55 °C

in operation -10 ... 55 °C

#### **Transport temperature**

-20 ... +80 °C (<100 hours), only switch on after a defrosting period of 24 hours.

#### **Storage temperature**

-20 ... +70 °C, only switch on after a defrosting period of 24 hours.

#### **Relative humidity**

Max. 95%, non-condensing

### Product package

#### **NRS 2-50**

1 level switch NRS 2-50

1 Installation & Operating Manual

#### **NRS 2-51**

1 level switch NRS 2-51

1 Installation & Operating Manual

## Example of name plate/identification

Name plate of NRS 2-50, top

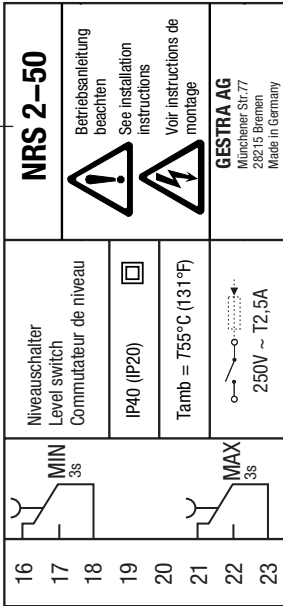

Type designation

Name plate of NRS 2-51, top

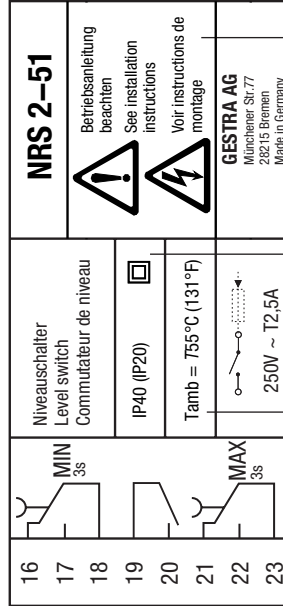

Safety note

Manufacturer

IP rating

External fuse for output contacts

Ambient temperature

Output contacts

Name plate, bottom

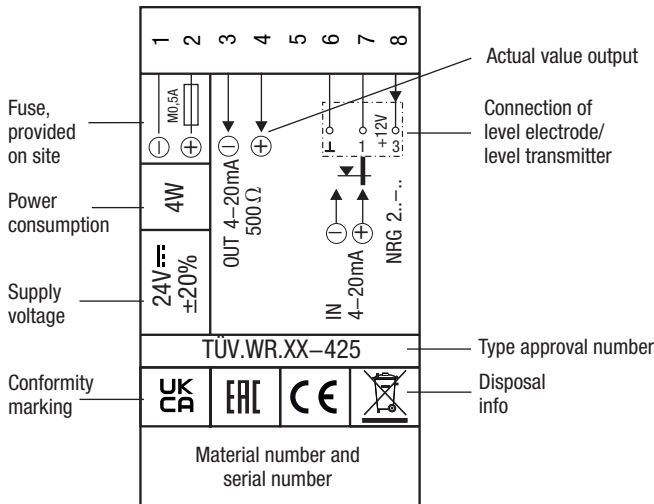

Actual value output

Connection of level electrode/ level transmitter

Fig. 1



## Installation

### Installation in the door of the control cabinet

The small panel adapter with rotary knob, stock code 441553, enables the switch to be installed in the door of a control cabinet.

The advantage of using the adapter is that the status is visible and alarms can be tested without opening the control cabinet door. When installed, the adapter has a rating of IP65. Please refer to the panel adapter Installation & Operating Manual 850625-xx for further information.



**Fig. 2**

## Dimensions of the NRS 2-50, NRS 2-51

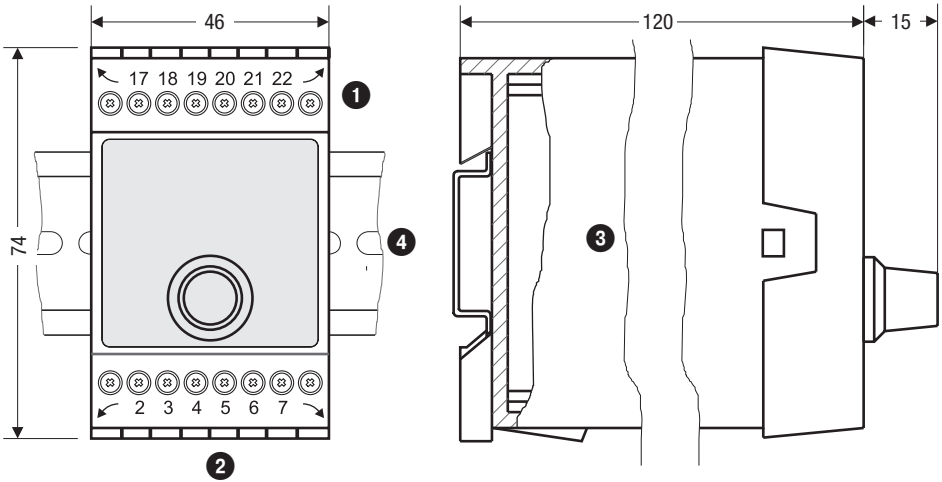

**Fig. 3**

### Key

- 1 Upper terminal strip
- 2 Lower terminal strip
- 3 Housing
- 4 Support rail TH 35, EN 60715

### Installation in a control cabinet

The NRS 2-50, NRS 2-51 level switch is clipped onto a type TH 35, EN 60715 support rail in the control cabinet. **Fig. 3**

## In the control cabinet: Wiring the level switch

### Wiring diagram for level switch NRS 2-50

#### NRS 2-50

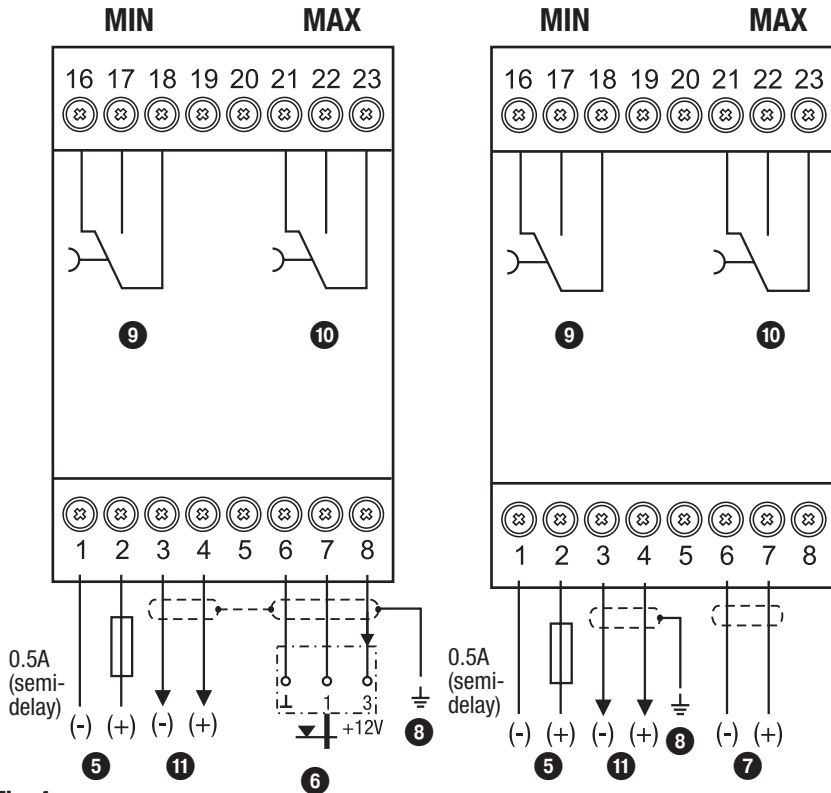

Fig. 4

#### Key

- 5 Supply voltage connection 24 V DC with 0.5A semi-delay fuse provided on site
- 6 Level electrode NRG 21-..; NRG 26-21.  
Max. three NRS/NRR 2-5.. units can be connected (connection in parallel).
- 7 Level transmitter NRGT 26-., 4-20 mA, with shield connection in terminal box.  
Max. three NRS/NRR 2-5.. units can be connected (series connection).
- 8 Central earthing point (CEP) in control cabinet
- 9 MIN output contact, off delay 3 seconds
- 10 MAX output contact, off delay 3 seconds
- 11 Actual value output 4-20 mA

## Wiring diagram for level switch NRS 2-51

### NRS 2-51

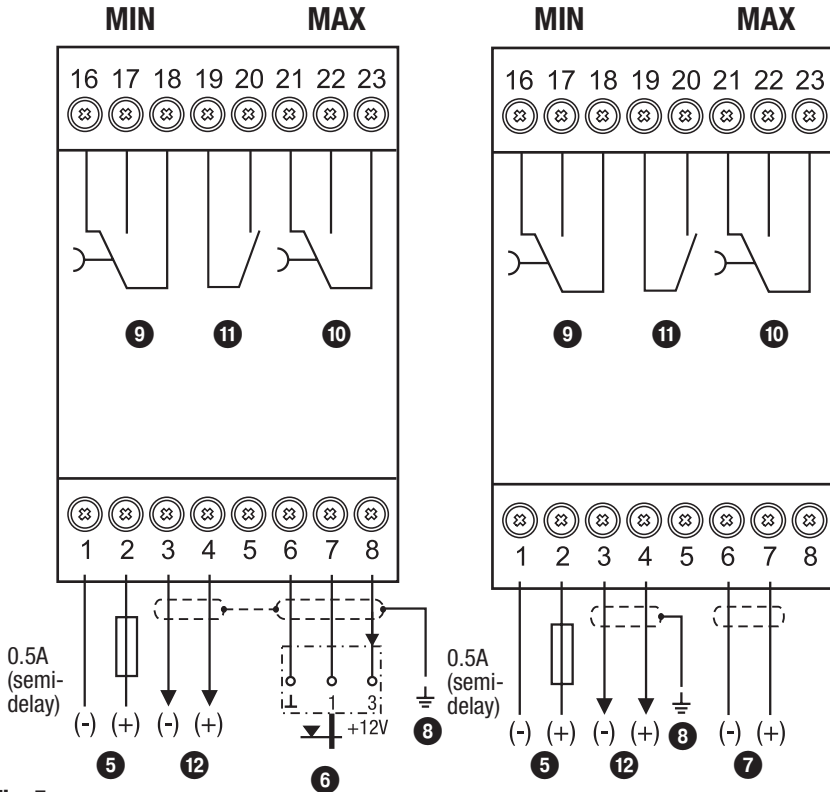

Fig. 5

### Key

- 5** Supply voltage connection 24 V DC with 0.5A semi-delay fuse provided on site
- 6** Level electrode NRG 21-...; NRG 26-21  
Max. three NRS/NRR 2-5.. units can be connected. (connection in parallel).
- 7** Level transmitter NRG 26-..., 4-20 mA, with shield connection in terminal box.  
Max. three NRS/NRR 2-5.. units can be connected (series connection).
- 8** Central earthing point (CEP) in control cabinet
- 9** MIN output contact, off delay 3 seconds
- 10** MAX output contact, off delay 3 seconds
- 11** Pump output contact
- 12** Actual value output 4-20 mA

## In the control cabinet: Wiring the level switch continued

### Supply voltage connection

The equipment is supplied with 24 V DC and has an external 0.5A semi-delay fuse. Please use a safety power supply unit with reliable electrical isolation.

This power supply unit must be electrically isolated from dangerous live voltages and meet the requirements for double or reinforced insulation in accordance with one of the following standards: EN 61010-1, EN 60730-1, EN 60950-1 or EN 62368-1.

### Connecting the output contacts

Wire the upper terminal strip ① (terminals 16-23) in line with the desired switching functions.

Provide an external 2.5A slow-blow fuse for the output contacts.

Switching off inductive loads produces surges that can have a major adverse effect on the operation of open and closed-loop control systems. Connected inductive loads must therefore have interference suppression (RC combination) as per the manufacturer's specifications.

### Connecting the level electrode/level transmitter

To connect the equipment, please use a shielded, multi-core control cable with a minimum conductor size of 0.5 mm<sup>2</sup>, e.g. LiYCY 4 x 0.5 mm<sup>2</sup>, maximum length 100 m.

Max. three NRS/NRR 2-5.. switches/controllers can be connected to one level electrode or one level transmitter.

Wire the terminal strip as shown in the wiring diagram. **Fig. 4, 5**

Connect the shield as shown in the wiring diagram.

Route the connecting cable between items of equipment separately from power lines.

### Connecting the actual value output

For connection, please use a shielded, multi-core control cable with a minimum conductor size of 0.5 mm<sup>2</sup>, e.g. LiYCY 2 x 0.5 mm<sup>2</sup>, maximum length 100 m.

Please note the maximum output load of 500 ohms.

Wire the terminal strip as shown in the wiring diagram. **Fig. 4, 5**

Connect the shield **once only** to the central earthing point (CEP) in the control cabinet.

Route the connecting cable between items of equipment separately from power lines.

Any item of equipment that you wish to connect to the terminals for the 4-20 mA actual value output must be certified to have at least double or reinforced insulation to EN 61010-1, EN 60730-1, EN 60950-1 or EN 62368-1 between the current loop and live parts of the equipment that are not supplied with safety extra-low voltage (SELV).



#### Attention

- Do not use unused terminals as support terminals.

### Tools

- Screwdriver size 3.5 x 100 mm, fully insulated to VDE 0680-1.

## In the system: Wiring the level electrode/transmitter

### Connecting the level electrode/level transmitter

The NRS 2-50, NRS 2-51 level switch can be combined in a circuit with the NRG 21-.. and NRG 26-21 level electrodes and the NRG 26-. level transmitter.

To connect the equipment, please use a shielded, multi-core control cable with a minimum conductor size of 0.5 mm<sup>2</sup>, e.g. LiYCY 4 x 0.5 mm<sup>2</sup>, maximum length 100 m.

Connect the shield as shown in the wiring diagram.



#### Attention

- Please bring the level electrode or level transmitter into service as described in the Installation & Operating Manuals of the NRG 21-..., NRG 26-21 and NRG 26-..
- Route the connecting cable between items of equipment separately from power lines.
- The level transmitter must be connected to its own dedicated power supply.

### Factory settings

#### Level switch NRS 2-50

- Off delay: 3 sec. (factory set)
- Input wired as a voltage input for connecting an NRG 21-.. or NRG 26-21 level electrode.
- MAX switchpoint AL.Hi = 80%
- MIN switchpoint AL.Lo = 20%
- Calibration value CAL.P = 100%
- Password PW: oFF

**Code switch** : All switches OFF

#### Level switch NRS 2-51

- Off delay: 3 sec. (factory set)
- Input wired as a voltage input for connecting an NRG 21-.. or NRG 26-21 level electrode.
- MAX switchpoint AL.Hi = 80%
- MIN switchpoint AL.Lo = 20%
- Switchpoint SP.Lo = 40%, pump on (fill), pump off (discharge)
- Switchpoint SP.Hi = 60%, pump off (fill), pump on (discharge)
- Calibration value CAL.P = 100%
- Fill control function
- Password PW: oFF

**Code switch** : All switches OFF

## Changing the factory settings



### Danger

The upper terminal strip of the equipment is live during operation.

There is a risk of serious injury due to electric shock!

Always **cut off power** to the equipment before working on the terminal strips (installation, removal, connecting cables).

## Switching the input and changing the function of the level electrode/transmitter

The input and function are determined by the setting of code switch **13**.

To make changes, you can access the code switch as follows:

▲ Switch off the supply voltage.

■ Remove the **lower** terminal strip. **Fig. 6**

- Insert a screwdriver on the right and left between the terminal strip and the front frame, as shown by the arrows.
- Release the terminal strip on the right and left sides, by turning the screwdriver in the direction of the arrow.
- Remove the terminal strip.

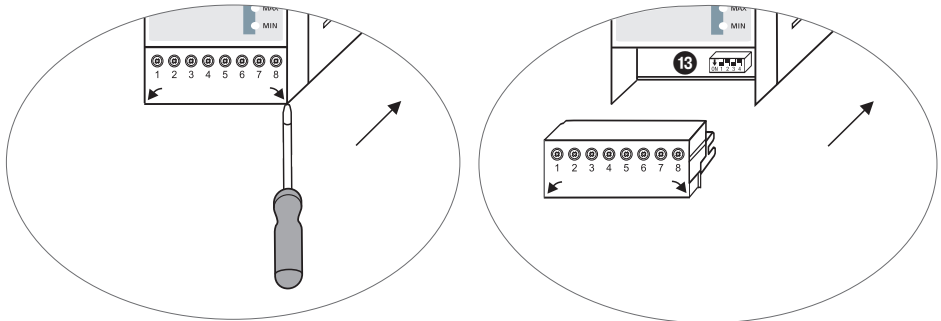

**Fig. 6**

When your changes are complete:

- Put on the lower terminal strip.
- Switch the supply voltage back on. The equipment restarts

### Switching the input and changing the function of the level electrode/transmitter continued

If you wish to switch the input or change the function, set switches S2 to S3 of code switch 13 as shown in the table Fig. 7.

Code switch 13		 Toggle switch, white
<b>Level switch NRS 2-50</b>		<b>S3</b>
Input for connecting level electrode NRG 21-.. or NRG 26-21		OFF
Input for connecting level transmitter NRGT 26-.*		ON
<b>Level switch NRS 2-51</b>	<b>S2</b>	<b>S3</b>
Input for connecting level electrode NRG 21-.. or NRG 26-21		OFF
Input for connecting level transmitter NRGT 26-.*		ON
Fill control	OFF	
Discharge control	ON	

**Fig. 7** grey = factory setting



#### Attention

\* When connecting the NRGT 26-. level transmitter, please set the upper and lower ends of the measuring range **only** in the transmitter. Please pay attention to the NRGT 26-. Installation & Operating Manual when doing this.

Do **not** change the settings of switches S1 and S4 on code switch 13!



## Operating the level switch

### Meaning of codes on the 7-segment display

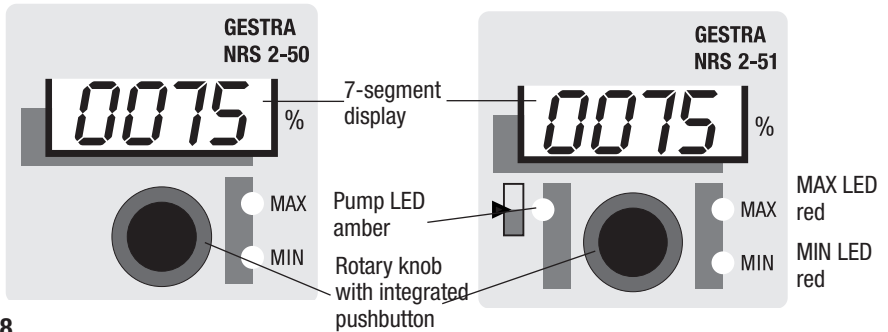

Fig. 8

Code	Meaning	
Appears when rotary knob is turned clockwise:		
AL.Hi	Alarm High	MAX switchpoint
AL.Lo	Alarm Low	MIN switchpoint
		Adjustable between 0 and 100% <b>C</b>
SP.Hi	Set point High	NRS 2-51 only: Switchpoint for pump off (fill), pump on (discharge), adjustable between 0 and 100% <b>C</b>
SP.Lo	Set point Low	NRS 2-51 only: Switchpoint for pump on (fill), pump off (discharge), adjustable between 0 and 100% <b>C</b>
tEst	Test	Output relays are tested
PW	Password	on = password protection is enabled oFF = password protection is disabled
	Factory setting	1902 (cannot be changed)

CAL.L	Calibrate L	Only if level electrode NRG 21-.. or NRG 26-21 is connected	Set lower end of measuring range
CAL.P	Calibrate %		Adjustable between $\geq$ 25 and $\leq$ 100%
CAL.H	Calibrate H		Set upper end of measuring range

#### Appears in parameterization mode

quit	Quit	Input is not confirmed
done	Done	Input is confirmed.

#### Appears in the event of malfunctions

E.005	Error	Level electrode/transmitter defective, measuring voltage/current too low
E.006	Error	Level electrode/transmitter defective, measuring voltage/current too high
E.012	Error	Lower and upper ends of measuring range wrong way round
E.013	Error	MIN switchpoint higher than MAX switchpoint

### Setting the measuring range

- A** Lower end of measuring range, adjustable
- B** Upper end of measuring range, adjustable
- C** Measuring range [mm] = xxx%
- D** Inactive range
- E** Maximum installed length at 238 °C

Set the lower and upper ends of the measuring range for your fill level measurement. This produces the measuring range **C**. Please convert the measuring range into percent!

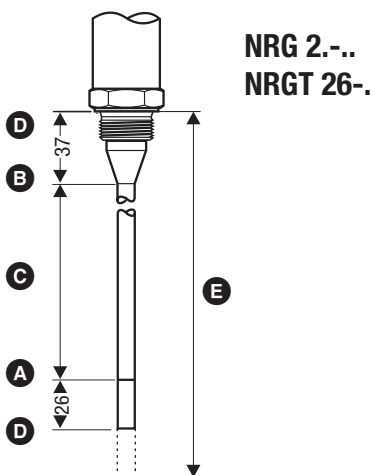

#### Attention

When connecting the NRGT 26-. level transmitter, please set the upper and lower end of the measuring range **only** in the transmitter.

# Bringing into service

## Setting parameters

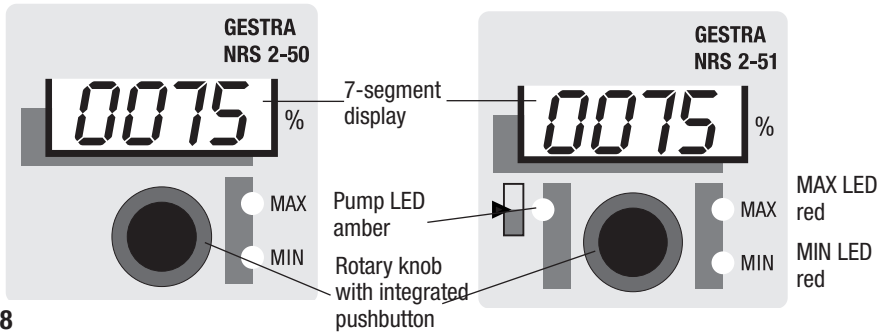

Fig. 8

Starting		
Action	Indication	Function
Switch on the supply voltage. Water level between MIN and MAX.	7-segment display shows software and equipment version	System test, takes approx. 3 sec.
	7-segment display shows actual value	System switches to operating mode

Setting parameters		
Action	7-segment display	Function
Turn rotary knob until desired parameter is shown	Display toggles between the parameter and the saved value.	The parameter is selected
Press and hold the pushbutton (on rotary knob)	First digit (000 <u>0</u> ) flashes.	Parameterization mode active. First digit can be changed.
Turn rotary knob	A new value is displayed.	Turning clockwise increases the value, turning anti-clockwise reduces the value.
Briefly press the pushbutton	2nd, 3rd or 4th digit flashes. (from right to left)	2nd, 3rd or 4th digit can now be changed using the rotary knob. Turning clockwise increases the value, turning anti-clockwise reduces the value.
When your entries are complete: Press and hold the button within 3 sec.	done is displayed. After this, the display toggles between the parameter and the new value.	Input is confirmed. The display shows the parameter once more.
<i>If you do not confirm your entry within 3 sec. or you do not make any further entries:</i>	quit is briefly displayed. After this, the display toggles between the parameter and the old value.	If you do not confirm, your entries will not be applied. Please repeat the procedure. If you do not confirm, the equipment switches back to the parameter.
Turn the rotary knob until the next parameter is shown. Or turn the rotary knob until the actual value is displayed. Or after 30s, the actual value is displayed automatically.		



If **password protection** is enabled, you must enter the password before you can change parameters. For the password, section "Password protection".

## Setting the measuring range

Level electrode NRG 2-.. only : Setting the measuring range, option 1		
Action	Indication	Function
Reduce water level down to lower end of measuring range A.		
Select parameter CAL.L.	After a short time, a hexadecimal number flashes.	Lower end of measuring range is calibrated.
Press the pushbutton.	The current hexadecimal number flashes.	
Press and hold the button again within 3 sec.	done is displayed. After this, the display toggles between CAL.L and the hexadecimal number. After a short time, 0000% appears.	Input is confirmed. (actual value output = 4 mA)
Fill tank to upper end of measuring range B.		
Select parameter CAL.H and press pushbutton.	After a short time, a hexadecimal number flashes.	Upper end of measuring range is calibrated.
Press the pushbutton.	The current hexadecimal number flashes.	
Press and hold the button again within 3 sec.	done is displayed. After this, the display toggles between CAL.H and the hexadecimal number. After a short time, 0100% appears.	Input is confirmed. (actual value output = 20 mA)

Level electrode NRG 2-.. only : Setting the measuring range, option 2		
Action	Indication	Function
Reduce water level down to lower end of measuring range A.		
Select parameter CAL.L.	After a short time, a hexadecimal number flashes.	Lower end of measuring range is calibrated.
Press the pushbutton.	The current hexadecimal number flashes.	
Press and hold the button again within 3 sec.	done is displayed. After this, the display toggles between CAL.L and the hexadecimal number. After a short time, 0000% appears.	Input is confirmed. (actual value output = 4 mA)
Fill tank up to at least 25% of the measuring range.		
Select parameter CAL.H.	After a short time, a hexadecimal number flashes.	Calibrate at a percentage of the measuring range, e.g. 25%.
Press the pushbutton.	The current hexadecimal number flashes.	
Press and hold the button again within 3 sec.	done is displayed. After this, the display toggles between CAL.H and the hexadecimal number. After a short time, 0100% appears.	Input is confirmed. (actual value output = 20 mA)
Select parameter CAL.P and set and save a percentage, e.g. 25%.	CAL.P interpolates the value measured at CAL.H to find 100% of the measuring range. CAL.P can be adjusted between 25 and 100%.	



### Note

- Adjusting the measuring range: The advantage of option 2 is that the tank only has to be partially filled.

# Operation, alarm and testing

## Setting switchpoints and indicators

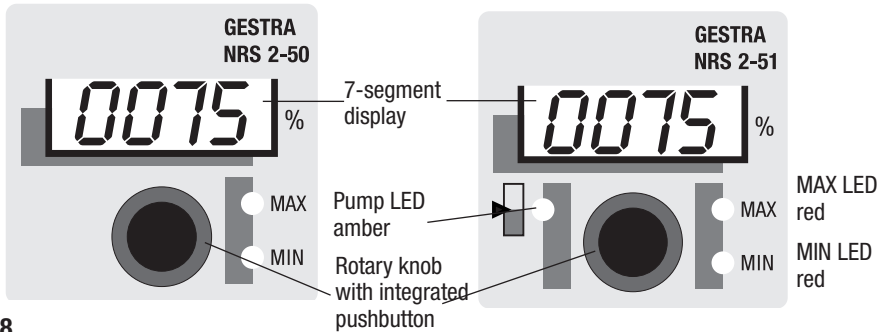

**Fig. 8**

Setting the MIN/MAX switchpoints	
Select parameter AL.Lo, enter and save the desired percentage.	MIN switchpoint is set between 0-100%
Select parameter AL.Hi, enter and save the desired percentage.	MAX switchpoint is set between 0-100%

Level switch NRS 2-51 only: Setting pump switchpoints (fill control)	
Select parameter SP.Lo, enter and save the desired percentage.	Pump ON switchpoint is set between 0-100%
Select parameter SP.Hi, enter and save the desired percentage.	Pump OFF switchpoint is set between 0-100%

Level switch NRS 2-51 only: Setting pump switchpoints (discharge control)	
Select parameter SP.Lo, enter and save the desired percentage.	Pump OFF switchpoint is set between 0-100%
Select parameter SP.Hi, enter and save the desired percentage.	Pump ON switchpoint is set between 0-100%

Operation		
Action	Indication	Function
Water level between MIN and MAX.	MIN and MAX LEDs are not lit	MIN output contacts 16/18 open, 17/18 closed. MAX output contacts 21/23 open, 22/23 closed.

MIN alarm		
Water level at or below MIN level switchpoint.	MIN LED flashes red	Off delay in progress.
	MIN LED lights up red	Delay time elapsed, MIN output contacts 16/18 closed, 17/18 open.

MAX alarm		
Water level at or above MAX level switchpoint.	MAX LED flashes red	Off delay in progress.
	MAX LED lights up red	Delay time elapsed, MAX output contacts 21/23 closed, 22/23 open.

### Indications

Level switch NRS 2-51 only: Fill control		
Water level below pump ON switchpoint.	Pump LED lights up amber.	Pump output contact 19/20 closed.
Water level above pump OFF switchpoint.	Pump LED is not lit.	Pump output contact 19/20 open.

Level switch NRS 2-51 only: Discharge control		
Water level above pump ON switchpoint.	Pump LED lights up amber.	Pump output contact 19/20 closed.
Water level below pump OFF switchpoint.	Pump LED is not lit.	Pump output contact 19/20 open.

### Checking the function of the MIN/MAX output contacts

Testing the MIN alarm and MAX alarm		
Action	Indication	Function
<b>In operating mode: Water level between MIN and MAX</b> Select Test parameter. Press and hold the pushbutton.	MAX LED flashes red	Off delay in progress.
	MAX LED lights up red for 3 seconds	MAX output contact 21/23 closed, 22/23 open.
	The MIN and MAX LED are not lit for 1 second	MIN output contact 16/18 open, 17/18 open. MAX output contact 21/23 open, 22/23 closed.
	MIN LED flashes red	Off delay in progress.
	MIN LED lights up red for 3 seconds	MIN output contact 16/18 closed, 17/18 open.
Test complete, release pushbutton. Equipment switches to operating mode.	Note: If you continue holding the pushbutton, the test sequence will start again. You can interrupt the test sequence at any time by releasing the pushbutton.	
Turn the rotary knob until the actual value is displayed. Or after 30s, the actual value is displayed automatically.		



#### Note

The actual value is shown on the 7-segment display.

## Password protection

Parameters can be password-protected from software version “S-13” onwards. The default password is 1902 and cannot be changed.

Enabling password protection		
Action	Display	Function
Turn the rotary knob until the entry PW is shown.	The display toggles between the parameter name and the parameter value.	Parameter selected.
Press and hold the pushbutton (on rotary knob).	PASS	Password entry is required.
Release and then press and hold the pushbutton once more.	First digit (0000) flashes.	Enter the password starting with the digit on the right.
Turn the rotary knob clockwise or anti-clockwise to enter the required digit.	000X	The first digit is entered.
Briefly press the pushbutton.	Second digit from the right flashes (000X).	The second digit can be entered.
Repeat the last two steps until the password has been entered in full.	The entered password is displayed (XXXX).	The password is entered in full.
Press and hold the pushbutton.	donE	The correct password was entered. The parameter may be edited.
	FAIL	The wrong password was entered. The parameter is still password-protected.
	quit	Processing time has elapsed. System switches back to the parameter. Password entry is cancelled.
Disabled password protection is re-enabled after 30 minutes with no activity (rotary knob). The password must be entered again. When the equipment is restarted, the parameters are password-protected, if password protection was previously enabled.		

# Troubleshooting

## Indications, diagnosis and remedies



### Attention

Please check the following before fault diagnosis:

#### Supply voltage:

Is the level switch supplied with the voltage specified on the name plate?

#### Wiring:

Does the wiring conform to the wiring diagram?

### Error codes on the 7-segment display

Error code	Error	Remedy
E.005	Level electrode defective, measuring voltage < 0.5 VDC	Check level electrode and replace if necessary. Check electrical connection.
	Level transmitter defective, measuring current < 4 mA	Check level transmitter and replace if necessary. Check electrical connection.
E.006	Level electrode defective, measuring voltage > 7 VDC	Check level electrode and replace if necessary. Check electrical connection.
	Level transmitter defective, measuring current > 20 mA	Check level transmitter and replace if necessary. Check electrical connection.
E.012	Lower and upper ends of measuring range wrong way round	Reset measuring range
E.013	MIN switchpoint higher than MAX switchpoint	Reset switchpoints
E.097	Walkthrough application error	Internal error. Replace equipment.
E.098	Walkthrough test error	Internal error. Replace equipment.
E.099	Internal test error	Internal error. Replace equipment.
<b>In the event of a malfunction, the MIN and MAX alarm is triggered.</b>		

All error codes not listed here are available as reserves.



### Attention

- For further diagnosis, please refer to the Installation & Operating Manuals for the NRG 21-..., NRG 26-21 and NRG 26-..



### Note

In the event of a malfunction in the level switch, the MIN and MAX alarm is triggered and the equipment restarts.

If the process is continually repeated, the equipment must be replaced.



## Further information

### Action against high-frequency interference

High-frequency interference can be caused by out-of-phase switching operations. If such interference occurs and results in sporadic failure, we recommend taking the following action to suppress interference:

- Provide inductive loads with RC combinations as per the manufacturer's specifications.
- Route the connecting cable to the level electrode or level transmitter separately from power lines.
- Increase the distance from sources of interference.
- Check the connection of the shield to the central earthing point (CEP) in the control cabinet.
- Suppress HF interference using hinged-shell ferrite rings.

### Replacing/taking the equipment out of service

- Switch off the supply voltage and **cut off power** to the equipment!
- Remove the upper and lower terminal strips. **Fig. 9**
  - Insert a screwdriver on the right and left between the terminal strip and the front frame, as shown by the arrows.
  - Release the terminal strip on the right and left sides, by turning the screwdriver in the direction of the arrow.
  - Remove the terminal strips.
- Release the white slider holder on the underside of the housing and remove the equipment from the support rail.

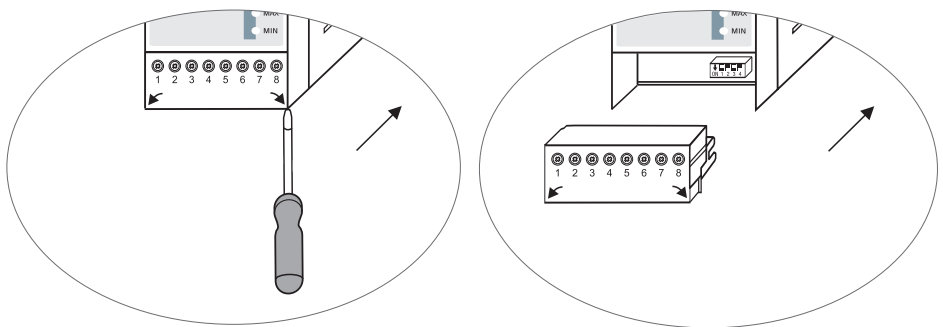

Fig. 9

### Disposal

The equipment must be disposed of in accordance with statutory waste disposal regulations.

In the event of malfunctions or faults that cannot be remedied with the aid of this Installation & Operating Manual, please contact our service centre or authorised agent in your country.

## **Declaration of Conformity Directives and Standards**

For more information on the conformity of the equipment as well as applied Directives and Standards please refer to our Declaration of Conformity and associated certificates and/or approvals.

The Declaration of Conformity can be found online at [www.gestra.com](http://www.gestra.com) and associated certificates can be requested from:

### **GESTRA AG**

Münchener Straße 77

28215 Bremen

Germany

Telefon +49 421 3503-0

Telefax +49 421 3503-393

E-mail [info@de.gestra.com](mailto:info@de.gestra.com)

Web [www.gestra.com](http://www.gestra.com)

Note that Declarations of Conformity and associated certificates lose their validity if equipment is modified without prior consultation with us.

**For your notes**



You can find our authorised agents around the world at: **[www.gestra.com](http://www.gestra.com)**

## **GESTRA AG**

Münchener Straße 77

28215 Bremen

Germany

Tel. +49 421 3503-0

Fax +49 421 3503-393

E-mail [info@de.gestra.com](mailto:info@de.gestra.com)

Website [www.gestra.com](http://www.gestra.com)

## **UK Importer:**

### **GESTRA UK Ltd**

Unit 1 Sopwith Park, Royce Close,  
West Portway Business Park, Andover,  
Hampshire SP10 3TS  
United Kingdom